

# ELECTRONIC CONTROL BOARD (PWA) REPLACEMENT

**IMPORTANT:** BE SURE THE VALVE CAM INDICATES "SERVICE" POSITION (See Figure 1) WHEN REPLACING THE ELECTRONIC CONTROL BOARD (PWA), TO ASSURE BOTH VALVE AND PWA ARE ORIENTED, OR TIMED, TO THE SAME CYCLE. If the valve is not in Service position, see step 13 below.

**NOTE:** When installing the electronic control board (PWA) on the faceplate, use care not to twist the circuit board, or force it onto the mounting pegs. Twisting could damage the printed circuits, or break the display glass.

1. Unplug the water softener's power supply from electrical power
2. Remove the faceplate cover to expose the valve.
3. Unplug the wiring connections from the back of the old Electronic Control Board (See Figure 2).
4. Carefully remove the old board by unsnapping it from its retainer tabs.
5. Carefully snap the new Electronic Control Board into the retainer tabs.
6. Reconnect the wiring to the new board (See Figure 2).
7. Plug the power supply into the electrical outlet. A number shows in the display for a few seconds, followed by a flashing '- - -'.

**NOTE:** If "- - -" is not flashing in the display, press and hold the SET button until the display changes, and repeat until a model code appears.

8. Use the UP (+) or DOWN (-) buttons to select the correct model code for your softener (see table below).

| Model Number      | Model Code to select |
|-------------------|----------------------|
| NSC30UD1          | A 27                 |
| NSC40UD1          | A-31                 |
| NST45UD1          | A-39                 |
| NST70UD1          | A-68                 |
| NSC30UD & NST30UD | PL22                 |
| NSR17CS           | CS17                 |

9. With the correct model code displayed, press the SET button several times, until a flashing "12:00 PM" and "PRESENT TIME" show in the display.
  10. Press the UP (+) or DOWN (-) buttons to set the present time. Up moves the display ahead; down sets the time back. Be sure AM or PM is correct.
- NOTE:** Press buttons and quickly release to slowly advance the display. Hold the buttons down for fast advance.
11. Press the SET button a few times, until the time appears on the display, but is not flashing.
  12. For information about programming additional features of the softener, consult your owner's manual.
  13. If the valve is not in Service position, press the RECHARGE button and hold for 3 seconds to start a recharge cycle. The display will flash "RECHARGE NOW." In about 2 hours the recharge cycle will be complete and the valve and electronic control board will be properly oriented together.

**NOTE:** To save time, use the manual advance procedures to properly time and check operation. See service information in the manual.

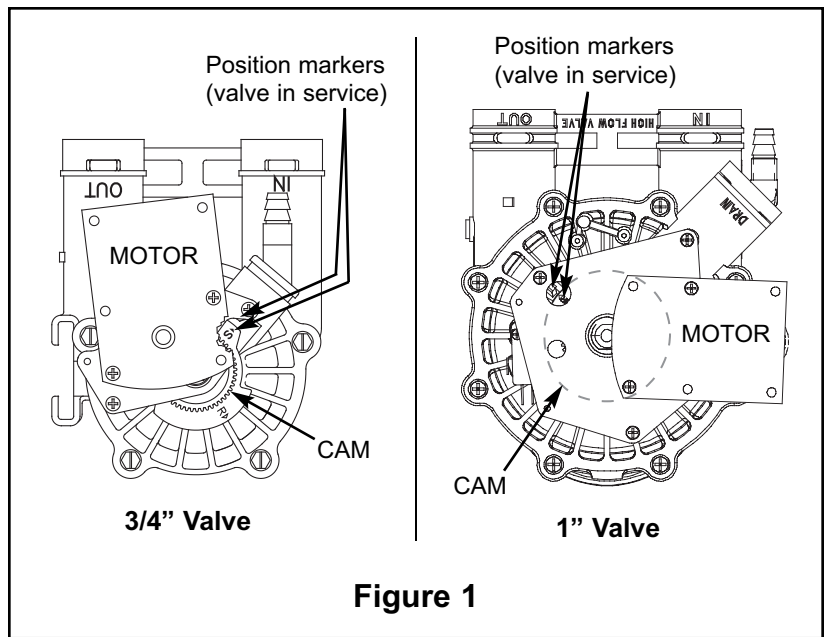

Figure 1

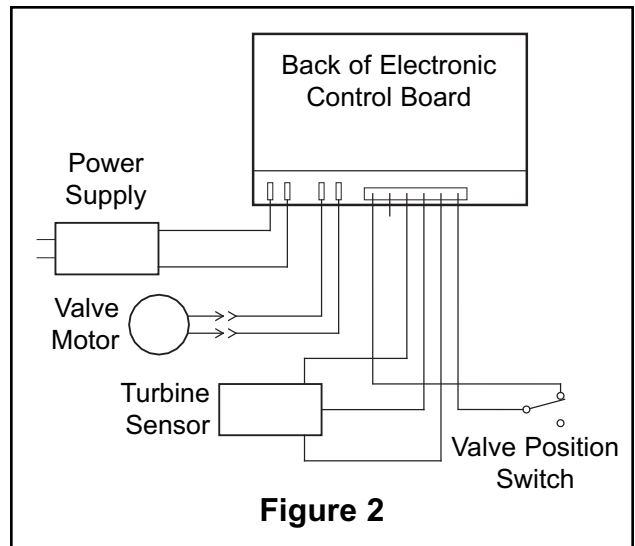

Figure 2

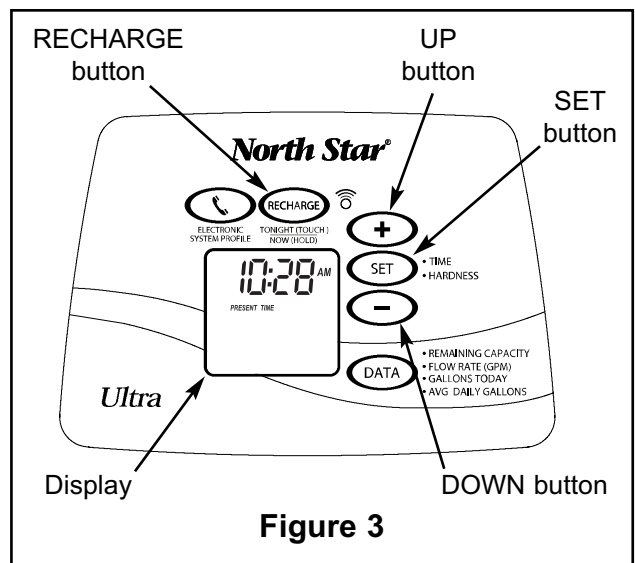

Figure 3