

# ELECTRONIC CONTROL BOARD (PWA) REPLACEMENT

**IMPORTANT:** BE SURE THE VALVE CAM INDICATES "SERVICE" POSITION (See Figure 1) WHEN REPLACING THE ELECTRONIC CONTROL BOARD (PWA), TO ASSURE BOTH VALVE AND PWA ARE ORIENTED, OR TIMED, TO THE SAME CYCLE. If the valve is not in Service position, see step 13 below.

**NOTE:** When installing the electronic control board (PWA) on the face-plate, use care not to twist the circuit board, or force it onto the mounting pegs. Twisting could damage the printed circuits, or break the LED glass.

1. Unplug the system's power supply.
2. Remove the system's top cover to expose the valve.
3. Unplug the wiring connections from the back of the old Electronic Control Board.
4. Carefully remove the old board by unsnapping it from its retainer tabs.
5. Carefully snap the new Electronic Control Board into the retainer tabs.
6. Reconnect the wiring to the new board.
7. Plug the power supply into the electrical outlet. A number shows in the display for a few seconds, followed by flashing "-----".

**NOTE:** If "-----" is not flashing in the display, press and hold the SELECT button until a model code appears.

8. Use the ↑ UP or ↓ DOWN buttons to set the correct model code for your system (see table below).

Water Filter Models	Model Code to Set
ETF2100-PF10, ETF2100-PF12, NSSFSSA, NSANSSA, NSTOFSSA, NSAPFSSA, NSAPFXLA, NSCCTOSSA, Universal Filter	HPF
Tannin Filters	STAn
ECWS, ECCWS	EC

9. With the correct model code displayed, press the SELECT button. The electronic controller will restart, briefly displaying the model code you set.
10. Press the ↑ UP or ↓ DOWN buttons to set the present time. Up moves the display ahead; down sets the time back. Be sure AM or PM is correct.

**NOTE:** Press buttons and quickly release to slowly advance the display. Hold buttons down for fast advance.

11. Press the SELECT button a few times, until the time appears on the display, but is not flashing.
12. Program additional water filter features, following instructions in your owner's manual.
13. If the valve is not in Service position, press the RECHARGE (or TOUCH/HOLD) button and hold for 3 seconds to start a recharge cycle. The filter cycles through the recharge positions during the next 30-90 minutes. After this the electronic controller and valve are properly oriented together.

**NOTE:** To save time, use the "manual advance" procedures to properly time and check operation. See "Troubleshooting" section of the manual.

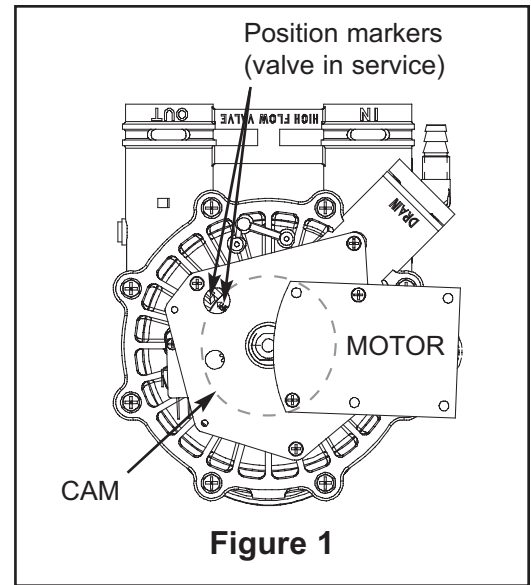

**Figure 1**

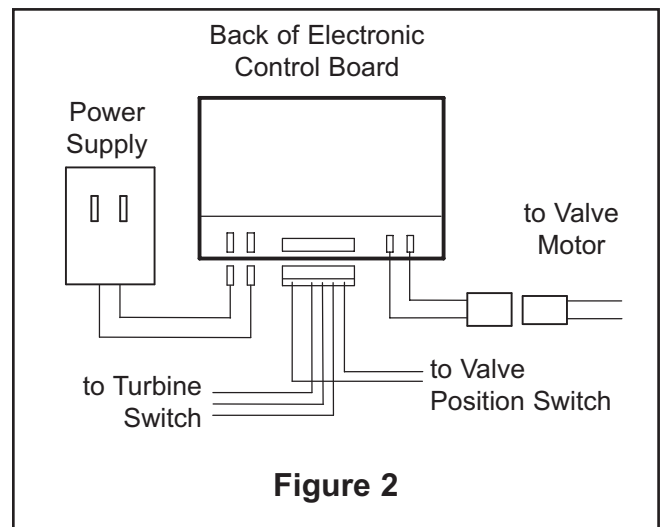

**Figure 2**

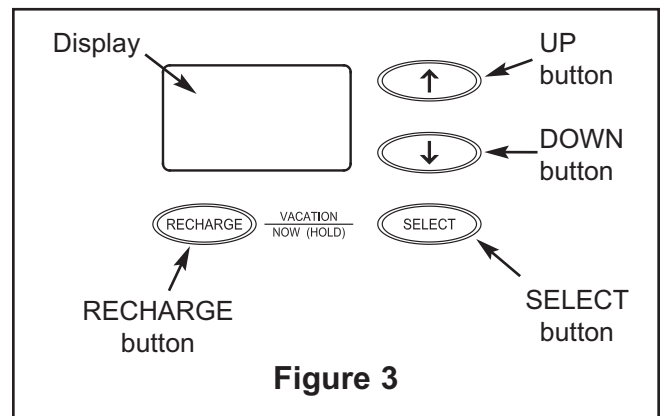

**Figure 3**