

ELECTRONIC CONTROL BOARD (PWA) REPLACEMENT

IMPORTANT: BE SURE THE VALVE CAM INDICATES “SERVICE” POSITION (See Figure 1) WHEN REPLACING THE ELECTRONIC CONTROL BOARD (PWA), TO ASSURE BOTH VALVE AND PWA ARE ORIENTED, OR TIMED, TO THE SAME CYCLE. If the valve is not in Service position, see step 12 below.

NOTE: When installing the electronic control board (PWA) on the faceplate, use care not to twist the circuit board, or force it onto the mounting pegs. Twisting could damage the printed circuits, or break the display glass.

1. Unplug the water softener’s power supply from electrical power.
2. Remove the top cover and salt lid to expose the valve.
3. Unsnap the faceplate from its support to expose the Electronic Control Board.
4. Unplug the wiring connections from the back of the old Electronic Control Board (See Figure 2) and remove the old board’s status light from its holder in the faceplate.
5. Carefully remove the old board by unsnapping it from its retainer tabs.
6. Carefully snap the new Electronic Control Board into the retainer tabs.

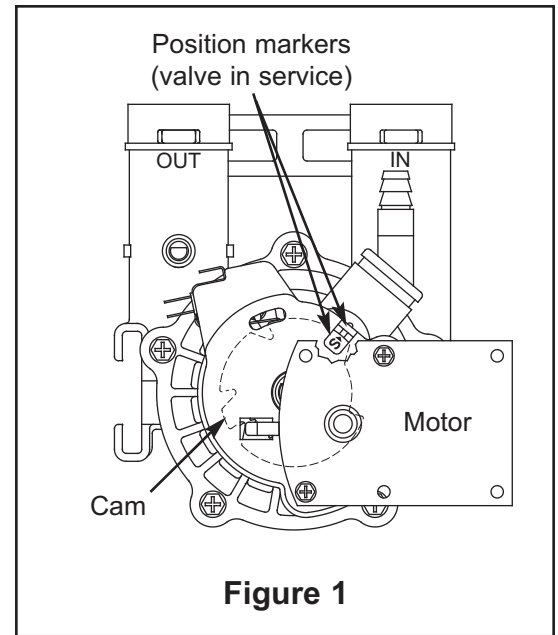

Figure 1

7. Reconnect the wiring to the new board (See Figure 2) and insert the new board’s status light into the holder in the faceplate.
8. Snap the faceplate back into its holder, being careful not to pinch any wires.
9. Plug the power supply into the electrical outlet. A model code (rH32) and a software version number (example: J4.0) briefly appear in the faceplate display. Then the words “SET TIME” appear and “12:00 PM” begins to flash.

10. Press the \triangle UP and ∇ DOWN buttons to set the present time. Up moves the display ahead; down sets the time back.

NOTE: Press buttons and quickly release to slowly advance the display. Hold the buttons down for fast advance.

11. Press the SELECT button, and continue programming hardness, recharge start time, salt type, and salt level. For details, consult your owner’s manual. When you have finished programming the controller, the time appears on the display, but is not flashing.

12. If the valve is not in Service position, press the RECHARGE button and hold for 3 seconds to start a recharge cycle. The display will flash “RECHARGE NOW”. In about 2 hours the recharge cycle will be complete and the valve and electronic control board will be properly oriented together.

NOTE: To save time, use the manual advance procedures to properly time and check operation. See “Troubleshooting” in the owner’s manual.

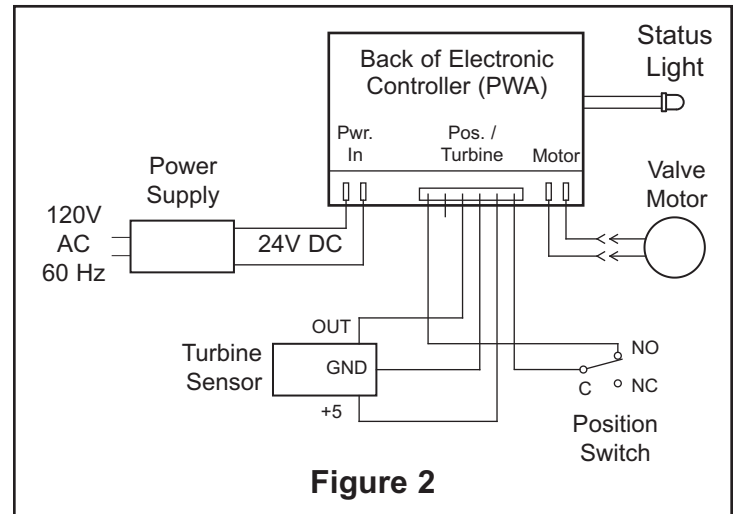

Figure 2

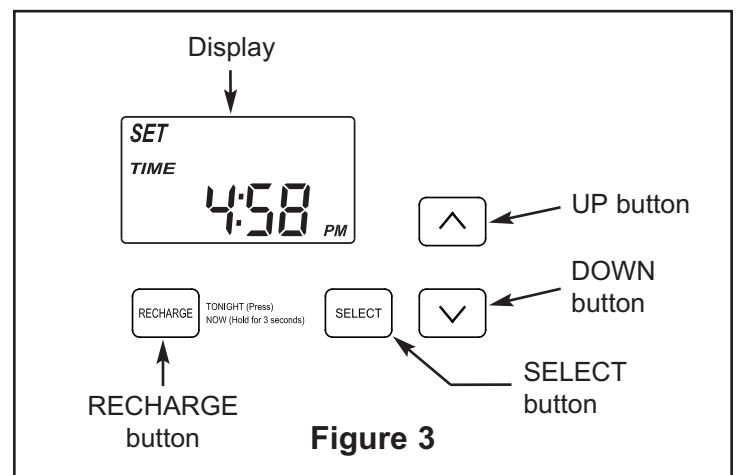

Figure 3