

SAFETY GUIDES:

- Check with your local public works department for plumbing codes. You must follow their guidelines as you install the whole home water filtration system.
- Do not use this system on water that is microbiologically unsafe or of unknown quality without adequate disinfection before or after the system.
- This system is only for use on COLD water (100°F / 38°C max.). Do not install on a hot water supply.
- Do not install this system where it will be exposed to outdoor weather or direct sun.
- Do not install or store this system where it will be exposed to temperatures below freezing. Water freezing in the system will damage it.
- The maximum operating water pressure of this system is 100 pounds per square inch. If your home water supply pressure exceeds 80 psi, install a pressure reducing valve before installing the whole home water filtration system.
- Handle with care. Dropping, knocking or scratching causes stress to clear material, which may result in breakage or leakage.
- Keep solvents and sprays away from clear material. Surface cracking and failure may result.

INSTALLATION LOCATION:

To filter all house water, install the filtration system on the main (COLD) supply water pipe near where it enters the house (See Figure 1).

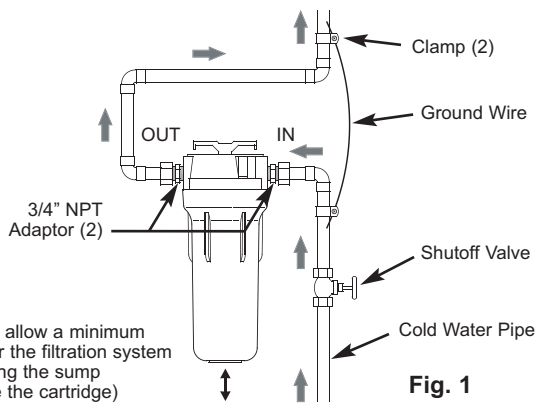

NOTE: Be sure to allow a minimum of 2" under the filtration system for removing the sump (to change the cartridge)

INSTALLATION STEPS:

1. Obtain two 3/4" male NPT adaptors (not included) of an appropriate size and type to adapt to the existing cold water supply pipe.
2. Shut off the water supply to the main pipe and open a high and low faucet in the system to drain the pipe.
3. Cut out a section of the COLD water supply pipe several inches long, as needed to install the filtration system as shown in Figure 1.
4. Apply 4 wraps of teflon tape to the threads of the 3/4" male NPT adaptors (not included) and carefully turn them into the filtration system's inlet and outlet ports.
5. With the IN side of the filtration system toward the incoming water, make connections, as shown in Figure 1. When tightening compression nuts, be sure to use a second wrench to hold the 3/4" NPT fitting while turning the nut.
6. Before turning the water back on, install the filter cartridge (not included), as shown in "FILTER CARTRIDGE INSTALLATION OR REPLACEMENT".
7. Fully open a cold water faucet downstream of the filtration system, then slowly turn the water supply back on and check for leaks.
8. Turn off the cold water faucet when the water flow becomes smooth.

GROUNDING INFORMATION:

The house cold water pipe is often used to ground electrical outlets in the home. Grounding protects you from electrical shock. Installing the filtration system may have broken this ground. To restore, buy and install a #4 copper wire across the filter, tightly clamped at both ends, as shown in Figure 1.

FILTER CARTRIDGE INSTALLATION OR REPLACEMENT:

Utilizes BRW2B, BRW2S, BRW2P, BRW2F, BRW2C and other standard 2-1/2" x 10" filter cartridges.

NOTE: A special wrench is included for removing the sump.

CAUTION: Never remove the sump with water pressure in the filtration system.

1. Turn the valve handle to the "BYPASS" position (See Figure 2). To relieve pressure in the filtration system, press the vent valve on top of the filtration system (See Figure 2). Some water may leak out of the vent valve as pressure is being relieved.
 2. Turn the sump to the left to remove from the head (See Figure 2). Be careful, as the sump is full of water. Do not lose the large o-ring seal.
 3. Be sure the inside of the sump is clean. Thoroughly wash with warm, soapy water and rinse.
 4. Remove the wrapper from the new filter cartridge and insert the filter cartridge into the sump. Some cartridges fit either way, while others fit only one way. Observe markings on the cartridge, or on the wrapper.
 5. Lightly lubricate the o-ring seal, in the sump, with silicone grease (available at your local hardware store). Be sure it is fully seated in the groove.
 6. Hold the sump up to the filter head, aligning the center hole in the cartridge with the protrusion on the bottom of the head.
- NOTE: If the sump will not tighten up to the head, you may have the cartridge in upside down or not centered in the sump. Take the cartridge out and check for correct orientation.
7. Being careful not to cross-thread, turn the sump to the right onto the filter head and tighten securely. Do not overtighten.
 8. Partially open a house faucet downstream of the filtration system. Then, turn the valve handle to the "FILTER" (ON) position (See Figure 3) and allow the filtration system to fill with water.
 9. Close the house faucet. Then, check for leaks between the sump and the head.
- NOTE: If a leak is occurring, turn off the water supply and depressurize the filtration system. Then, remove the sump and check the o-ring for cuts, flat spots, etc., and sealing surfaces for foreign material. Clean the o-ring and lubricate with silicone grease. Carefully press into the groove in the sump.
10. If using a Taste and Odor Cartridge: A taste and odor cartridge contains activated carbon, a black powder. After the new cartridge is installed, open the faucet downstream of the filter housing and allow carbon particles to purge from the cartridge. Close the faucet when you no longer see "fines" (discoloration) in the filtered water, or approximately 2 - 3 minutes.

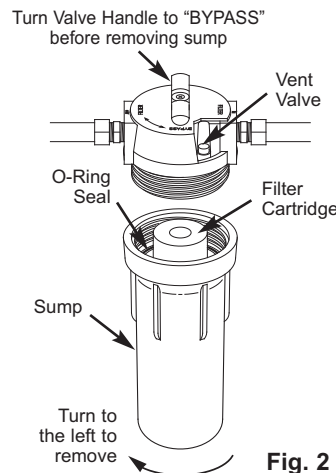

Fig. 2

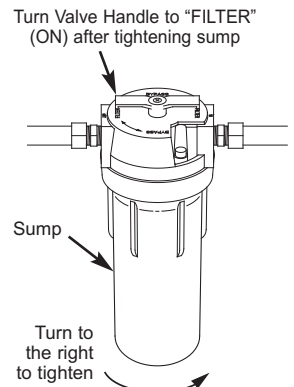

Fig. 3



BRW2VC is Tested and certified by NSF International against NSF/ANSI Standard 42 for materials and structural integrity requirements.

REPLACEMENT PARTS	
Part No.	Description
BROR009	O-Ring
BRUSW09	Sump Removal Wrench

ONE YEAR LIMITED WARRANTY ON WHOLE HOME WATER FILTRATION SYSTEM (except filter cartridges)

Warrantor: Water Channel Partners, 1890 Woodlane Drive, Woodbury, MN 55125

Warrantor guarantees, to the original owner, that the Whole Home Water Filtration System, when installed and maintained in accordance with the instructions, will be free from defects in materials and workmanship for a period of one year from date of installation. If, within the first year, a part proves, after inspection, to be defective, Warrantor will, at its sole option, either replace or repair the part without charge except installation charges. Labor to maintain the equipment is not part of the warranty. Filter cartridges, which are expendable, are not covered by the warranty.

TO OBTAIN WARRANTY PARTS, SIMPLY CALL 1-800-218-6172 for assistance. This warranty applies only while this product is in use in the United States.

General Provisions

The above warranties are effective provided the Whole Home Water Filtration System is operated at water pressures not exceeding 100 psi, and at water temperatures not exceeding 100°F; provided further that the Whole Home Water Filtration System is not subject to abuse, misuse, alteration, neglect, freezing, accident or negligence; and provided further that the Whole Home Water Filtration System is not damaged as the result of any unusual force of nature such as, but not limited to, flood, hurricane, tornado or earthquake.

Warrantor is excused if failure to perform its warranty obligations is the result of strikes, government regulation, materials shortages, or other circumstances beyond its control.

THERE ARE NO WARRANTIES ON THE WHOLE HOME WATER FILTRATION SYSTEM BEYOND THOSE SPECIFICALLY DESCRIBED ABOVE. ALL IMPLIED WARRANTIES, INCLUDING ANY IMPLIED WARRANTY OF MERCHANTABILITY OR OF FITNESS FOR A PARTICULAR PURPOSE, ARE DISCLAIMED TO THE EXTENT THEY MIGHT EXTEND BEYOND THE ABOVE PERIODS. THE SOLE OBLIGATION OF WARRANTOR UNDER THESE WARRANTIES IS TO REPLACE OR REPAIR THE COMPONENT OR PART WHICH PROVES TO BE DEFECTIVE WITHIN THE SPECIFIED TIME PERIOD, AND WARRANTOR IS NOT LIABLE FOR CONSEQUENTIAL OR INCIDENTAL DAMAGES. NO WARRANTOR DEALER, AGENT, REPRESENTATIVE, OR OTHER PERSON IS AUTHORIZED TO EXTEND OR EXPAND THE WARRANTIES EXPRESSLY DESCRIBED ABOVE.

Some states do not allow limitations on how long an implied warranty lasts or exclusions or limitations of incidental or consequential damage, so the limitations and exclusions in this warranty may not apply to you. This warranty gives you specific legal rights, and you may have other rights which vary from state to state. This warranty applies to consumer-owned installations only.